



Cadillac & LaSalle Club Potomac Region Caddie Chronicle April 2013



DIRECTOR'S MESSAGE BY VINCE TALIANO

2013 OFFICERS:

REGIONAL DIRECTOR
NEWSLETTER EDITOR
WEBSITE MANAGER
VINCE TALIANO

ASSISTANT REGIONAL DIRECTOR
CAR SHOW COORDINATOR
DAN RUBY

NATIONAL DIRECTOR
NEWSLETTER COLUMNIST
JACK MCCLAW

SECRETARY
ASSOCIATE NEWSLETTER EDITOR
VALLEY FORGE REGION LIAISON
SANDY KEMPER

TREASURER
HARRY SCOTT

ACTIVITIES DIRECTOR
NEWSLETTER COLUMNIST
R. SCOT MINESINGER

MEMBERSHIP DIRECTOR
DEBBIE TAYLOR

OTHER KEY POSITIONS:

SUMMER PICNIC HOST
J. ROGER BENTLEY

AUTOMOBILIA AUCTIONEER
HAMPTON ROADS REGION LIAISON
GEORGE BOXLEY

NEWSLETTER COLUMNIST
RITA BIAL-BOXLEY

SHOW WEEKEND COORDINATOR
SHELLEY CHADICK

NEWSLETTER COLUMNIST
CHRIS CUMMINGS

NEWSLETTER COLUMNIST
JIM GOVONI

CAR SHOW SPONSOR AND HOST
DANIEL JOBE & CAPITOL CADILLAC

NEWSLETTER COLUMNIST
TOM MCQUEEN

HONORARY MEMBER
NEWSLETTER COLUMNIST
VERN PARKER

CENTRAL VA REGION LIAISON
NEWSLETTER COLUMNIST
CHUCK PIEL

CAR SHOW MASTER OF CEREMONIES
NATIONAL CLC ADVISOR
NEWSLETTER COLUMNIST
RICHARD SILLS

Our sincerest condolences go out Mark & Nan Brodsky on the recent passing of their son, Steve. Our thoughts and prayers are with the entire Brodsky family including Steve's widow, Anna, and their two young children.



If anyone is planning to attend the Valley Forge Region's Car Show on Saturday April 20th at General Sales Cadillac in West Chester, PA and interested in caravanning from the area, please contact Lynn Gardner at lygardner@FDIC.gov.

Preparations are well underway for our 22nd Annual Spring Car Show and Automobilia Auction at Capitol Cadillac. The registration flier is included in this issue. Weather-permitting, we are expecting another great turnout. For more information, contact Dan Ruby, Car Show Coordinator, at danruby@clcpotomacregion.org or 301-894-8026.



Dan Ruby, son of our good friend Henry Ruby, has decided to sell a number of his late father's Cadillac parts, at the family home in Temple Hills, Maryland. Dan will be holding an open garage sale on Sunday, April 21 2013 starting at 9:00 am. There are Cadillac parts, automobile parts, generators, starters, radiators, a complete 1959 390 engine & transmission w/ 68,000 miles, a 1962 390 engine, some tools, books and odds and ends. If any member is interested in attending, please contact Dan at danruby@clcpotomacregion.org or 301-894-8026.

Vince Taliano



Cadillac & LaSalle Club Potomac Region Caddie Chronicle April 2013



2013 CALENDAR OF EVENTS

DATE	TIME	EVENT	LOCATION	CONTACT INFORMATION
Apr 4-7 Thu-Sun		AACA Southeastern Spring Meet	Charlotte NC	www.aaca.org
Apr 6 Sat	10:00 am – 3:00 pm	VCCA Free State Region's Spring Tour	National Cryptologic Museum Annapolis Junction MD	Mike Natale at 410-583-9171, 443-465-7492 or mrnatale@verizon.net
Apr 14 Sun	8:00 am – 3:00 pm	AACA Brandywine Region Swap Met	Mid-Atlantic Antique and Collector Car Center Kennett Square PA	Andrew Barbour at 302-738-4483
Apr 20 Sat	9:00 am – 3:00 pm	CLC Valley Forge Region Spring Car Show	General Sales Cadillac West Chester PA	Ronnie Hux at 610-268-3388, 302-745-8850 or cadiman59@aol.com
Apr 21 Sun	8:00 am – 4:00 pm	4th Annual Spring Car Truck Motorcycle Show	Adventure Park USA New Market MD	Janine Weiger at 301-865-6800 or http://adventureparkusa.com/
Apr 24 - 28 Wed-Sun	Gates open daily at 7:00 am	Spring Carlisle	Carlisle PA	717-243-7855 or www.carsatcarlisle.com
Apr 28 Sun	8:00 am – 3:00 pm	Spring Fever Classic & Custom Car, Truck, and Tractor Show	Fauquier High School Warrenton VA	Chris at 571-437-3752 or fhsbandcarshow@fauguierband.org
Apr 29 Mon	7:30 pm – 9:30 pm	Potomac Region Monthly Meeting	Capitol Cadillac Greenbelt MD	Vince Taliano at 301-258-8321 or vincetaliano@clcpotomacregion.org
May 3-4 Fri-Sat		60th Annual AACA Fredericksburg Region ODMA Meet	Fredericksburg VA	Andy Gotchel at 540-775-4177 or adwaynel@aol.com
May 4 Sat		Berwyn Heights Day Parade	Berwyn Heights MD	Ed Murphy at emurphy@town.berwyn-heights.md.us
May 5 Sun	9:00 am – 3:00 pm	22nd Annual Capitol Cadillac Spring Car Show/ Automobilia Auction	Capitol Cadillac Greenbelt MD	Car Show: Dan Ruby at danruby@clcpotomacregion.org or 301-894- 8026 Automobilia Auction: Vince Taliano at 301-258-8321 or vincetaliano@clcpotomacregion.org
May 11 Sat	8:00 am – 4:00 pm	55th Annual AACA Apple Blossom Meet	Jim Barnett Park Winchester VA	Bob Engle at 540-247-8634, bengle58@gmail.com or www.sraaca.org
May 18 Sat	9:00 am – 3:00 pm	CLC Central PA Region's 24th Annual Spring Show	Kelly Cadillac Lancaster PA	Art Archambeault at 717-557-6974 or artarchambeault49@gmail.com
May 18 Sat	10:00 am – 3:00 pm	City of Fairfax Antique Car Show	City Hall Fairfax VA	www.nvrg.org



Cadillac & LaSalle Club Potomac Region Caddie Chronicle April 2013



DATE	TIME	EVENT	LOCATION	CONTACT INFORMATION
Jun 1 Sat	9:00 am – 3:00 pm	8th Annual Spring BOPC Car Show Presented by Delaware Valley Oldsmobile Club	Granite Run Mall Media PA	dvocinfo@yahoo.com
Jun 3-7 Wed-Sun		CLC National Driving Tour Hosted by the Northern California Region	Starting from San Francisco CA	http://www.cadillaclasalleclub.org
Jun 8 Sat		24th Annual Orphan Car Tour	Starting from Williamsport MD	Jon Battle at 540-364-1770, TourDirector@orphancartour.org or www.orphancartour.org
Jun 8 Sat	9:00 am – 3:00 pm	CLC Raritan River Region Car Show	Royal Cadillac Florham Park NJ	Joe Manna at joem@rrrcl.org
Jun 15 Sat	Registration from 9:30 am - 11:00 am	Southern Maryland Sun Music Festival Poker Run	Calvert County Fairgrounds Barstow MD	Jim Zirakian at jimmyz@somdsunmusicfest.org or http://somdsunmusicfest.org/poker-run/
Jun 16 Sun	10:00 am – 3:30 pm	40th Annual Sully Plantation Father's Day Antique and Classic Car Show	Sully Plantation Chantilly VA	Bill Worsham at 703-250-5474, billworsham@aol.com or www.gwcmodeleda.org
Jun 23 Sun		CLC Valley Forge Region Annual Fall Car Show	Delaware Cadillac Wilmington DE	http://www.vfrcl.org/calendar.html
Jul 6 Sat	11:00 am – 4:00 pm	9th Annual Picnic with Lincoln Mercury friends	J. Roger Bentley's Brinklow MD	R. Scot Minesinger at rscotm@cox.net or 703-283-2021
Jul 12 Fri		4th Annual Collector Car Appreciation Day	All across the USA	www.SEMASAN.com/ CollectorCarAppreciationDay
Jul 13 Sat	9:00 am – 3:00 pm	7th Annual CLC Inter-Regional Meet	AACA Museum Hershey PA	Art Archambeault at 717-557-6974 or artarchambeault49@gmail.com
Jul 28 Sun	10:00 am – 3:00 pm	10th Annual VCCA Free State Region's Annual Car & Truck Show	Meadowbrook Regional Park Lutherville MD	Hank at 410-377-8331, dankerus@comcast.net or grand1917@comcast.net
Jul 31- Aug 3 Wed-Sat		CLC Grand National Meet Hosted by by the New England Region	Boston MA	http://www.nercl.com/grandnational
Aug 10 Sat	10:00 am – 3:00 pm	39th Annual Metro Chapter Buick Club All-GM Show	Montgomery College Rockville MD	Cory Correll at 240-686-0229 or corydraw@gmail.com
Aug 29 - Sep 1 Fri-Sun		CLC Grand European	Noordwijkerhout Netherlands	www.cadillacclub.nl
Sep 1 Sun	10:00 am – 3:00 pm	Vern Parker's 25th Annual Invitation Antique Car Show	Spring Hill Recreation Center McLean VA	www.vernparker.com
Sep 29 Sun	9:00 am – 3:00 pm	All-GM Show Hosted by the Royal GTOs	King Buick GMC Gaithersburg MD	Bill Sandusky at 301-570-3517 or 301-801-7519 (Day of Show)
Sep 29 Sun		CLC Valley Forge Region Annual Fall Car Show	Peddler's Village Lahaska PA	www.vfrcl.org/upcoming_events.htm

More events will be added each month.

Visit www.clcpotomacregion.org/eventslisting.htm where show flyers can be downloaded.



Cadillac & LaSalle Club Potomac Region Caddie Chronicle April 2013



22nd Annual Capitol Cadillac / CLC Potomac Region Spring Car Show & Automobilia Auction Sunday May 5, 2013

Car Registration:

9:00 am – 12:00 pm

Please read the Car Show Rules on
the following page

Car Show Hours:

9:00 am – 3:00 pm

Auction starts at 12:00 pm

6500 Capitol Drive
Greenbelt, MD 20770
301-441-9600

LOCAL DIRECTIONS:

From Capital Beltway (I-495/95)

- Use Exit 23 - Kenilworth Avenue Rte 201, proceed South on Kenilworth Avenue to first exit - Greenbelt Road, Route 193
- At light, proceed East on Greenbelt Road - Rte 193 (left)
- At traffic light make left onto Walker Drive (**TGI Friday's** Restaurant on corner)
- Make an immediate right onto Capitol Drive (Dealership is on your left)

From Baltimore-Washington Parkway (Rte 295)

- Use Exit for Rte 193 (Greenbelt Road)
- Proceed West on Rte 193 - Greenbelt Road
- Make first right after underpass onto Capitol Drive (Dealership is on your right)

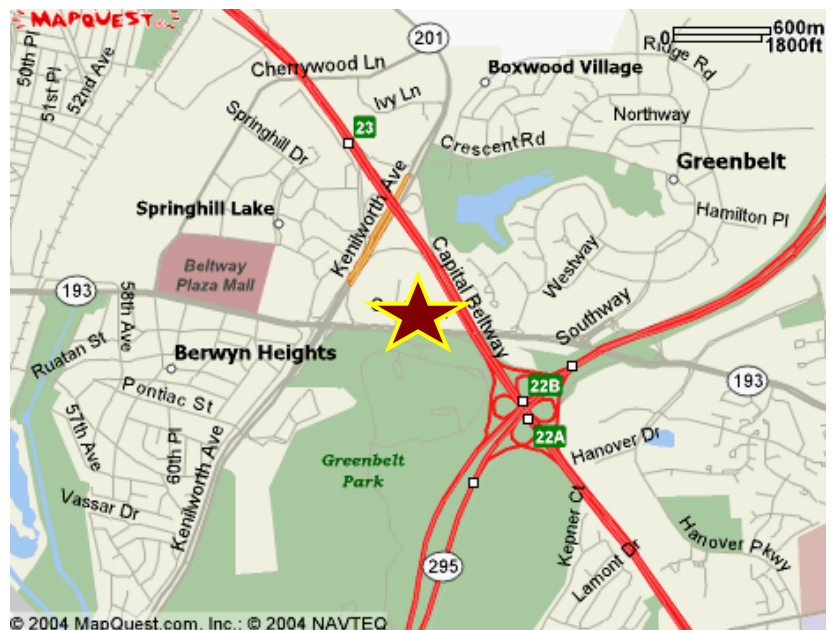
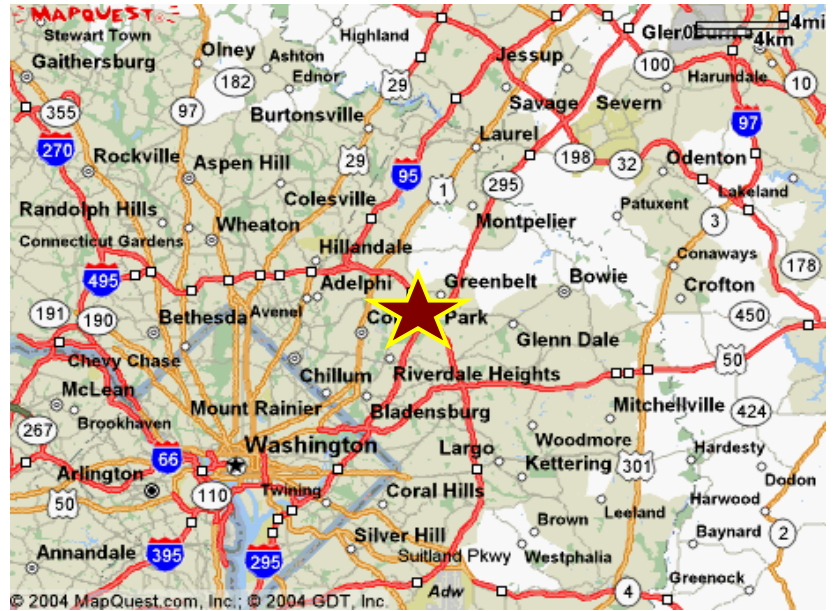

FOR FURTHER INFORMATION:

Dan Ruby

Car Show Coordinator

danruby@clcpotomacregion.org or 301-894-8026

Visit us on the web!
www.clcpotomacregion.org



Cadillac & LaSalle Club Potomac Region Caddie Chronicle April 2013



Spring Car Show Women's Lunch

The Spring Car Show is a big event for our club. The event starts at 9:00 am, includes an Automobilia Auction and ends with the Awards Ceremony at 3:00 pm. But, is all this chrome and talk of the best tires making you sleepy? Wishing you had stayed home? Join us for lunch for just the women attending our show. We will walk over to TGIFridays (right next door to the show) and celebrate Cinco de Mayo! We will reserve a big table for 1:00 pm-3:00 pm, and have asked for separate checks so that we each will pay for our own lunch. Hope you can come! It will be nice to meet all of you and visit with those we have already met. For more information, email Debbie Taylor at debbietaylor@clcpotomacregion.org



Car Show Rules

- **Rain or Shine:** The car show will take place rain or shine. No refunds.
- **Safety:** If a vehicle has fluid drips or leaks, the owner must bring absorbent material or drip pans to avoid slippery conditions and to protect the showroom floor or show field parking lot. **The Potomac Region reserves the right to prevent any cars with excessive fluid leaks from entering the show field.** It is recommended that a working fire extinguisher be in every vehicle.
- **Judging / Parking Rules:** The Potomac Region reserves the right 1) to determine each vehicle's judging class and 2) each vehicle's placement in the show field. **There will be no parking on the grassy areas whatsoever, due to sprinkler heads and possible rut damage.** Vehicles will be peer judged by the individual owners of the registered cars. Registrants will be able to judge vehicles in all classes, including their own. 1st, 2nd and 3rd place awards will be given to winning vehicles in each class.
- **Lunch Tickets:** Each registered car owner will receive one free lunch ticket. The lunch ticket will entitle the person to receive the following from Red, Hot & Blue BBQ, who will be on-site serving food:
 - 1) One Beef, Chicken or Pork Sandwich
 - 2) One Side order of Beans or Potato Salad and Cole Slaw
 - 3) One Drink including bottle waterAnyone without a lunch ticket will pay Red, Hot & Blue directly at the time of their purchase.



Cadillac & LaSalle Club Potomac Region Caddie Chronicle April 2013



Car Show Registration Form

<u>Judging Classes</u>	<u>Other Awards</u>
Class A: 1902 – 1942 Cadillac Class B: 1927 – 1940 LaSalle Class C: 1946 – 1958 Cadillac Class D: 1959 – 1964 Cadillac Class E: 1965 – 1970 Cadillac Class F: 1971 – 1976 Cadillac Class G: 1977 – 1986 Cadillac Class H: 1987 – 1996 Cadillac Class I: 1997 – Current Cadillac Class J: Professional Vehicles Class K: Modified Vehicles	<ul style="list-style-type: none">• Dealer's Choice• Best Pre-War• Best Post-War• Best of Show• Ladies Choice• Long Distance (Driven Cars Only) <p>A vehicle receiving "Best of Show" may also receive an award in its class, but will not be eligible to receive "Best Pre War" or "Best Post War" at the same show.</p>

Registration Form

Make checks payable to **CLC Potomac Region** and mail with completed registration form to:
Harry Scott, Treasurer
14421 Aden Road
Nokesville, VA 20181-3122

Name: _____

Address: _____

City: _____ State: _____ Zip: _____

Vehicle Registration Fee: (Up to Apr 28th: \$15/per car - After Apr 28th: \$20/per car)

Circle Make: CAD LAS Model: _____ Year: _____ Class: _____

Circle Make: CAD LAS Model: _____ Year: _____ Class: _____

Circle Make: CAD LAS Model: _____ Year: _____ Class: _____

Check this box if you do not want your vehicle(s) judged



Cadillac & LaSalle Club **Potomac Region** **Caddie Chronicle** **April 2013**



**9th Annual Pot-luck Summer Picnic
w/Lincoln & Mercury Friends
J. Roger Bentley's Tudor House
20110 New Hampshire Ave
Brinklow, MD**

**July 6, 2013 (Saturday)
11:00 am to 4:00 pm
Rain Date Sunday July 7, 2013 (based on lawn conditions)
Phone: 301-924-6331**

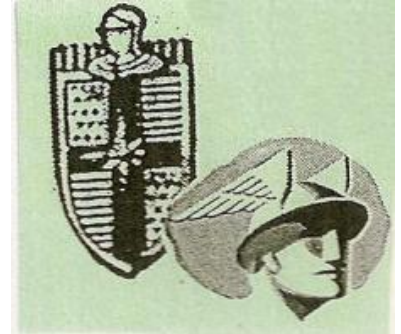

Please bring your favorite picnic food, and if you have a favorite dessert you want to share with others, please bring that as well. The club will provide soft drinks, water, ice, serving tables, plates, cutlery, etc. Feel free to bring special beverages of your choice. **Please RSVP by July 1st indicating the dish that you will be bringing.**

Also please bring folding chairs or a blanket to sit on. Parking is on the grass under the trees in the front yard.

DIRECTIONS: from Capitol Beltway, 1-495, take exit 28 north towards White Oak. Continue on route 650 (New Hampshire Ave) about 25 minutes, past Ashton, past Goldmine Road. On the left about 1,000 yards is 20110 New Hampshire Ave. Turn in the driveway and veer off to the left to find a parking space under the trees. Buffet will be set up inside the Garage-Mahal.

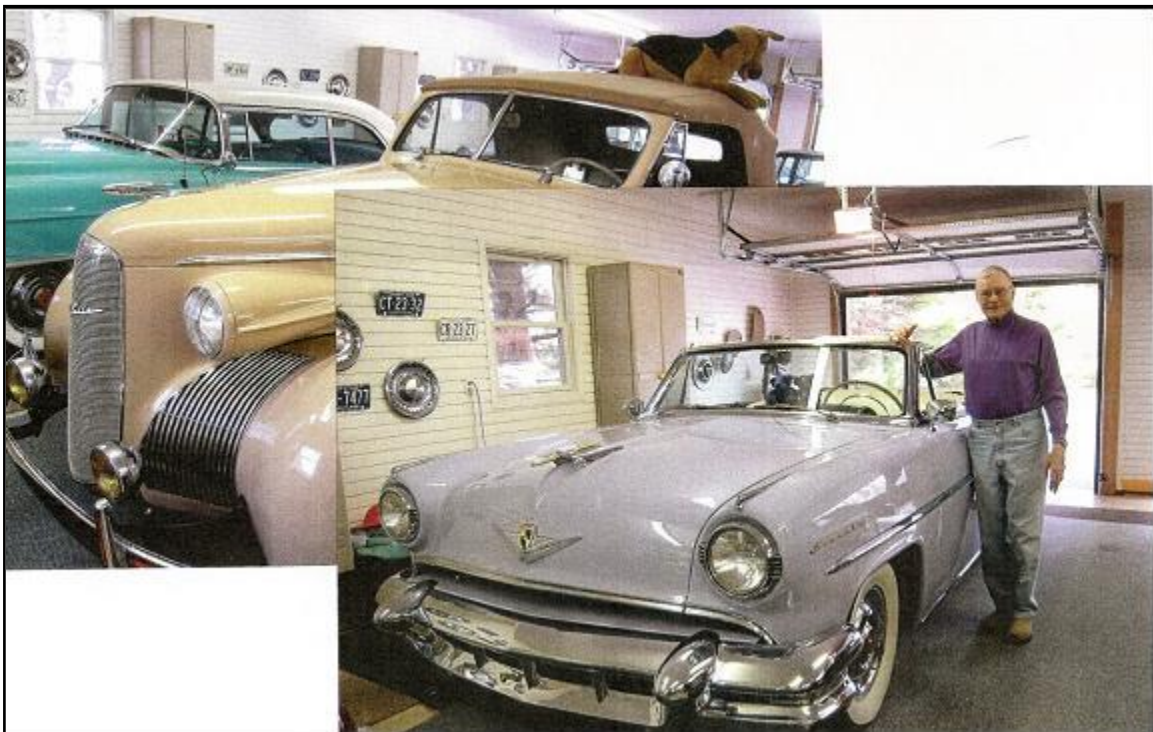

Visit us on the web!
www.clcpotomacregion.org



Cadillac & LaSalle Club

Potomac Region

Caddie Chronicle

April 2013



MARCH 16, 2013 MEETING MINUTES **BY SANDY KEMPER**

PLACE: USA Parts Supply, Kearneysville, WV

TIME: 12:30 PM

PRESIDING: Secretary Sandy Kemper

ATTENDANCE: Hans Decker, Jack McClow, Scot Minesinger, Chuck Piel, David Piel and Dan Ruby

DIRECTOR'S REMARKS: Sandy thanked everyone for attending, and introduced the group to one of our newest members, Hans Decker. Hans was recently featured in the ***Caddie Chronicle*** in a Letter to the Editor discussing a trip to South America. Sandy announced that the next meeting will take place on **the last Monday in April, April 29th at Capitol Cadillac**. He turned the meeting over to Dan Ruby who spoke on behalf of the club and thanked Mike Cannon, owner of USA Parts, for his generous hospitality. All of the USA Parts employees were friendly and helpful making the day worthwhile for everyone in attendance. Thanks to Scot Minesinger for organizing the event.

SECRETARY'S REPORT: The Minutes from the February meeting were not read since they will be published and distributed to all members in the March, 2013 newsletter.

TREASURER'S REPORT: The Treasurer's Report covered the year to date time period. The Region's income was \$130.49. The total expenses for the same time period were \$13.00.

MEMBERSHIP REPORT: Our current 2013 membership total is 195 members. Our newest members are John Dever, Annandale, VA; Joe Palmore, Rockville, MD; Nick Deoudes, Queenstown, MD and Douglas Jemal, Washington, DC. John recently purchased a 1965 Flower Car. Joe owns a 1962 Park Avenue. Nick has a 2006 XLR and a 2009 CTS. Douglas is the owner of a 1939 LaSalle Opera Coupe and 1947 Series 62 Convertible. Welcome!

ACTIVITIES REPORT: The following activities were discussed:

1. Recent Events:

- **40th Annual Atlantic City Classic Car Show & Auction, Atlantic City Convention Center, Atlantic City, NJ, Fri-Sun, Mar 1-3rd.** Dan Ruby attended this show and provided some observations of what he saw there.
- **40th Annual AACA Chesapeake Region Parts Meet, Howard Co Fairgrounds, West Friendship, MD, Sat, Mar 9th.** Many Baltimore Area CLC-PR members are AACA Chesapeake Region members too and worked at the show. Several other PR members were seen shopping at the meet. Continuing a trend that began several years ago the show had an increase in the number of vendors and good crowds of attendees.

2. Upcoming PR Events:

- **Annual Spring Car Show & Automobilia Auction, Capitol Cadillac, Greenbelt, MD, Sun, May 5th.** See show flyer for more details.
- **9th Annual Pot-luck Summer Picnic w/Lincoln & Mercury Friends, Roger Bentley's Home, Brinklow, MD, Sat, Jul 6th.** See details in April newsletter.



Cadillac & LaSalle Club

Potomac Region

Caddie Chronicle

April 2013



3. Other Upcoming Events: The following events were mentioned:

- **43rd Annual AACA Sugarloaf Mountain Region Parts Meet, Carroll County Agriculture Center, Westminster, MD, Fri-Sat, Mar 29-30th.** This is a new location for this meet which is popular with our members.
- **AACA Southeastern Division Spring Meet, Charlotte, NC, Thu-Sun, Apr 4-7th.** This meet is held at the Charlotte Motor Speedway. The number of flea market vendors is huge and the impressive car corral is located on the Speedway's track.
- **CLC Valley Forge Region Spring Car Show, General Sales Cadillac, West Chester, PA, Sat, Apr 20th.**

OLD BUSINESS:

- The Region's officers have discussed starting another matching contribution campaign, like we did in 2010 and 2011, to provide much needed funds to the CLCMRC Building Fund. The campaign will begin later this year once the details are worked out and approved by the officers.
- The Valley Forge Region has begun to accept credit cards for registration fees to their car shows and events. Sandy Kemper has contacted the VFR but is awaiting the details of their arrangements to see if this is something that could be done in our Region also.

NEXT MEETING: Monday, April 29th at 7:30 PM at Capitol Cadillac in Greenbelt, MD

ADJOURNMENT: Meeting adjourned at 1:15 PM.

Thanks to USA Parts Supply for hosting our March 2013 meeting.

USA PARTS SUPPLY
304-724-6600
1800-872-2013
261 INDUSTRIAL BLVD
KEARNEYSVILLE, WV 25430



Cadillac & LaSalle Club Potomac Region Caddie Chronicle April 2013



**TRIP TO USA PARTS SUPPLY IN WEST VIRGINIA WAS VERY VALUABLE
STORY BY R. SCOT MINESINGER
PHOTO BY SANDY KEMPER**



**From L to R: Lynn Gardner, David Piel, Chuck Piel and Jack McClow
check out a 1966 Fleetwood Brougham**

On Saturday March 16th, the Potomac Region held its second tour of USA Parts Supply in Kearneysville, West Virginia. USA Parts Supply is one of the preeminent Cadillac parts suppliers in the country. The purpose of the trip was to become more familiar with how USA Parts Supply can help us restore our Cadillacs. In addition to their parts, they also have used Cadillacs for sale and some nice parts cars too. The trip was fun and very educational to say the least. The staff at USA Parts was extremely helpful. As with most worthwhile events, it was too short.

A benefit to attending the event was that USA Parts Supply offered discounts on all sales conducted that day, even backordered parts, plus they didn't charge shipping and handling. The USA Parts Supply facility is a 20,000 square foot building with a large yard containing parts cars, many sets of doors, bumpers, and other parts that can be stored outside, and used quality Cadillacs for sale. The yard appeared to have an endless sea of bumpers, doors and fenders for every year Cadillac. The interior of the building had row after row of parts neatly organized with every part imaginable on the shelves. For more information on USA Parts Supply, visit their website at <http://usapartssupply.com> or call them at 1-800-872-2013.



Cadillac & LaSalle Club Potomac Region Caddie Chronicle April 2013



IN THE NEWS



Bills to Provide for Single License Plate in Maryland Die as Legislature Adjourns

Maryland legislation (H.B. 562) to require the issuance of a single motor vehicle license plate died when the legislature adjourned for the year. The bill, favored by state hobbyists, required that the single registration plate be attached on the front of tractors and on the rear of all other vehicles. A second bill (H.B. 577) to allow the front plate to be stored inside the vehicle if the vehicle was manufactured without a means to secure and display a front plate also died.

Thank you to all who participated in supporting these bills.



Two-time Indy 500 winner Al Unser Jr. will serve as Grand Marshall at this year's Keel's & Wheel's Show in Seabrook, Texas. What is hot off the presses news and being kept from their promotional folks as kind of an open secret for the show is that the car that he drove to open the 76th Indy 500 in 1992, a 1993 Cadillac Allanté Pace/Parade car, will also be on display. Al Unser Jr. not only drove this particular 1993 Allanté at Indy, but also at the opening of the new Belle Isle Raceway for the Detroit Grand Prix XI two weeks later. The 1993 Allanté was brought to Houston, Texas by Nick Ferrantino in 2006 and was displayed at last year's Keel's & Wheel's Show next

to the table where Bobby Unser was signing posters. Bobby Unser signed the dash of this Allanté, as the hope is that Al Unser Jr. will place his signature next to his uncle's. This Allanté is all original and has just over 35,000 miles.



Cadillac & LaSalle Club Potomac Region Caddie Chronicle April 2013



**IN MEMORIAM: DAVID CAMMACK
1928-2013
BY DANIEL STROHL
HEMMINGS DAILY**

To own just one Tucker takes a certain amount of luck and determination. To own three – along with the world’s most extensive collection of Tucker memorabilia, Tucker mechanical parts, and most of the Tucker engineering drawings – takes dedication, and nobody in the world showed more dedication to the marque than collector David Cammack, who died Sunday, April 7th at the age of 85.

As David LaChance related in his profile of Cammack in the June 2007 issue of *Hemmings Classic Car*, Cammack got



**David Cammack hosting attendees from
the 2009 CLC National Driving Tour
Photo by Bill Edmunds**

his first glimpse of a Tucker in 1948 at the Mayflower Hotel in Washington, D.C. Cammack, then a teenager, had gone to see the prototype, known as the Tin Goose, and its massive 589-cu.in. flat-six engine, but lost interest in the car when the company failed. It wasn’t until 1972 that Cammack, by then a successful real estate investor, bought his first Tucker, number 1022. The other two – numbers 1001 and 1026 – came in quick succession over the next couple of years, but almost more important than the cars were the ephemera that came with them or that Cammack later bought: one of two Tucker test chassis, a variety of prototype and production Tucker/Aircooled Motors engines, and about 50,000 blueprints for just about every component that made up a Tucker. “I don’t think there was any doubt that (Preston Tucker) was serious about building a car,” Cammack told us for the profile. “I think all these drawings provide that.”



Cadillac & LaSalle Club

Potomac Region

Caddie Chronicle

April 2013



Over the years he had made attempts at cataloging the entire collection of blueprints and engineering drawings – going so far as to hire assistants for that task – but about 90 percent of the collection reportedly remains uncataloged.

Cammack housed his collection in a nondescript building in Alexandria, Virginia, and though he never advertised its existence, he always entertained visitors who came to see what Cammack considered the most comprehensive as well as the largest Tucker collection. “I wouldn’t want it if I had to keep it in a safety deposit box,” he told the Smithsonian for its video profile on him. “Who wants something like that? You can’t enjoy it and nobody else can. That’s not my nature.”

That said, after restoring all three cars, he never drove them. He did, however, lend two of them to the production of Francis Ford Coppola’s film, ***Tucker: The Man and His Dream***. Cammack maintained that after his death the collection would head to the Antique Automobile Club of America’s (AACAA) museum in Hershey, Pennsylvania. He was a patron of the AACAA museum and even bought one wing of the building to house his collection during the museum's design and original construction.

There will be a memorial mass for David Cammack at 10 a.m. on Thursday, April 18th, at the St. Mary’s Church in Alexandria, Virginia.

[EPILOUGE BY JEFF GURSKI AND VINCE TALIANO: Dave was a kind and generous man and a good friend to the Potomac Region. He welcomed members and friends of the Region at least three different times, including attendees of the 2009 CLC National Driving Tour. The most recent time he welcomed members to tour his collection was when CLC New England Region Director Chris Micili was in town and Sandy Kemper and Jack McClow arranged a visit for Chris. Our region (and many other local car clubs) will miss him, for he was the world's foremost living authority on the 1948 Tucker. Such a loss for us all!]



Cadillac & LaSalle Club Potomac Region Caddie Chronicle April 2013



"THE AIR CONDITIONING JUST NEEDS A CHARGE" STORY & ILLUSTRATION BY R. SCOT MINESINGER

We have all read the famous line, "The a/c just needs a charge", on eBay or other classic car for sale ads. The more straightforward advertisements read along the lines of this is a factory a/c car, all/most components are present, but it is not operational. Almost any classic will sell for far more than the cost of "just a charge" (around \$200) with operational air conditioning than without operational air conditioning. Cadillacs equipped with climate control (1964 and newer) present the added challenge of enabling the air conditioning system to operate along with an operational air conditioning system. The cost of a repairing and providing a fully reliable functioning Cadillac with climate controlled air conditioning can range from \$200 all the way to \$5,000 with parts and labor.

Driving a Cadillac with climate control should be a pleasure, complete with a temperature controlled cabin and smooth ride. If it is not, then something is wrong and requires repairs. Unfortunately, the climate-controlled Cadillac repair market demand does not support a business to attend to this small need, so when my Cadillac needed this work done, I had to learn how to repair it myself.

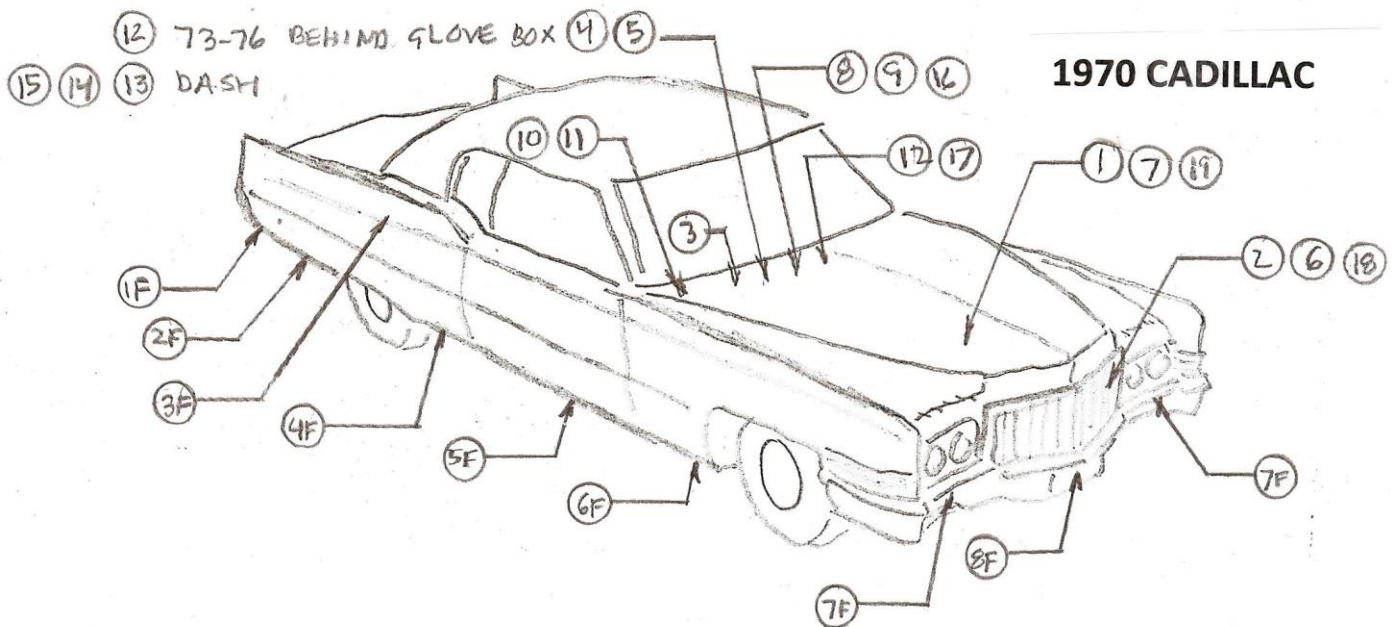

Diagram 1

Diagram 1 shows the location of the climate control major components (1-19). The climate control system for 1964 through 1979 Cadillacs operates on a similar principle and utilizes similar components. Diagram 2 displays the list of parts including approximate costs from a trusted vendor (does not include labor to diagnose/install). Component numbers one through 11 plus 18 and 19 would be required on any car with air conditioning and heating. Components 12 through 17 are unique to climate controlled systems.



Cadillac & LaSalle Club Potomac Region Caddie Chronicle April 2013



The Cadillac climate control systems are more comfortable than most modern systems because they are quieter and operate with less disruption to driver and passengers. They are well worth repairing. However, Diagram 2 below illustrates that the repair of an air conditioning system on an older car can be quite expensive.

Climate control major components

1. Compressor	\$400 re-built
2. Condenser	\$300 new
3. Evaporator	\$400 new
4. Expansion valve	\$70 new see vra for 73-76
5. POA (STV) 134	\$150 new (RVA 73-76)
6. Receiver/dry	\$100 new
7. Hoses (all 3)	\$300 new
8. Heater core	\$200 new
9. Heater valve	\$55 new
10. Blower motor	\$90 new
11. Blower wheel	\$50 new
12. Power servo	\$250 re-built (programmer)
13. Dash switch	\$380 re-built w/transducer
14. Dash switch	\$280 re-built no transducer *
15. Transducer	\$150 re-built
16. Master switch	\$120 re-built (64-86 only) *
17. Actuators	\$90 new/re-built
18. Miscellaneous	\$200 hose, clips, mounts etc
19. R134 charge	\$100 new

Total \$3,135.00 Most all clim cont parts
(* not included in total, duplicates for 64-68, total for 64-68 close)

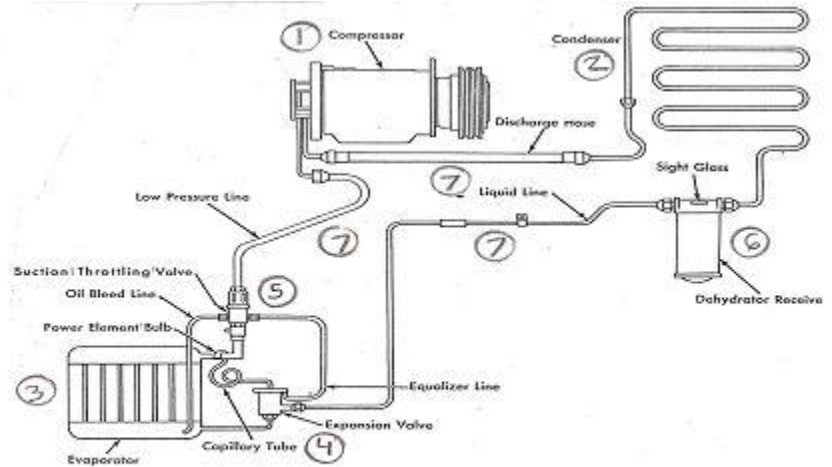

Diagram 2

In general, due to control failures or rodent infestations, the climate control systems in classic Cadillacs often stopped working 20 years ago, and continued to deteriorate. However, the compressors are surprising durable. I have repaired the climate control systems on a '66, '67, two '70s, a '74 and a '75 Cadillac, and only two compressors had to be replaced. As a general rule on any 30+ year-old Cadillac, all rubber parts should be replaced if original. This includes the three refrigeration hoses and the vacuum tubing.

When the refrigeration circuit is opened up, it is a good idea to also replace the expansion valve, service throttling valve (POA), and receiver (item numbers 4, 5, & 6). One advantage of the climate control cars is that it is likely the controls failed before the refrigerant circuit, whereas a non climate control car, the refrigeration components probably wore out and require replacement. Most Cadillac climate control systems require the dash and power servo (items 12 & 13 (or 12, 15, & 16)) to be replaced. The dash unit and power servo are only available as rebuilt from used parts.

The key to maintaining your climate control system once it is operational is to repair it immediately if anything fails, and to use it regularly. Once a component fails the entire system deteriorates with or without use and becomes more difficult later to repair trying to diagnose multiple system component failures.

I have started repairing climate control systems, body to frame bushings and other work on a limited basis for club members. Feel free to contact me for more information.



Cadillac & LaSalle Club Potomac Region Caddie Chronicle April 2013



**OWNER OF "CADILLAC RANCH" IN TEXAS INDICTED ON CHILD SEX ABUSE CHARGES
STORY BY REUTERS
PHOTOS BY VISIONS OF AMERICA/UIG VIA GETTY IMAGES
APRIL 11, 2013**



Texas oil millionaire Stanley Marsh 3, an oil company heir and arts promoter known for the "Cadillac Ranch," was indicted on Thursday on more than a dozen counts involving sexual molestation of children. Marsh, 75, faces up to 20 years in prison on each of the counts if convicted on the charges that include sexual assault, indecency with a child and sexual performance by a child.

Marsh, who considers the Roman numerals "III" to be pretentious and prefers the suffix "3," is best known as the owner of the iconic **Cadillac Ranch**, a work of public art that features 10 brightly painted Cadillac cars buried nose-first in the ground along Interstate 40 in the Texas Panhandle.

The indictment charges Marsh with offenses involving six victims, Lubbock County District Attorney Matt Powell said. The allegations first surfaced in a civil lawsuit filed by two boys who were 15 and 16 years old when the incidents allegedly happened in 2010.



Cadillac & LaSalle Club Potomac Region Caddie Chronicle April 2013



"The indictments filed today are mere allegations," Marsh's Houston attorneys, Paul Nugent and Heather Peterson, said in a statement. "Now that we have notice of the specific allegations, we will commence our investigation, which will be thorough and vigorous." The incidents allegedly occurred in Amarillo, about 120 miles north of Lubbock. The district attorney for Potter County, which forms part of the Amarillo area, recused himself from the case and Powell made the presentation to the grand jury.



"We'll look at it to see if it needs to go to trial, or if we should make an offer in the case," Powell said. Powell said Marsh's failing health would be one of the factors affecting his decision. Marsh suffered a stroke in 2011 and is said to be in poor health.

The iconic Cadillac Ranch, Marsh's most famous creation, has become a part of American culture as the subject of everything from a Bruce Springsteen song to an episode of the animated television show "King of the Hill."

Marsh has been no stranger to allegations of child sexual assault. A separate lawsuit filed against March in 2012 claimed he paid 10 teenage boys to engage in sexual acts both at his office in Amarillo and at his home, called 'Toad Hall,' a reference to the Kenneth Grahame novel 'The Wind in the Willows.'

Other allegations of improper sexual activity with young boys date back to the mid 1990s. At one point Marsh served a 10-day jail term after pleading no contest to misdemeanor charges.



Cadillac & LaSalle Club Potomac Region Caddie Chronicle April 2013



CADDIE CLASSIFIEDS

Cars For Sale

NEW ARRIVAL 1947 Series 75 Sedan, Non-Divider with Jump Seats – Dark Blue – 89,564 miles – Same owner since the early 1960s – Restorable or for parts – See pictures at <http://www.clcpotomacregion.org/47cadillacforsale.htm> – **Best Offer**

NEW ARRIVAL 1948 Series 60 Special – Black – 75,911 miles – Not driven since 1968 – Restorable or for parts – Additional complete 1948 Series 60 Special free to purchaser of this car (strictly a parts car that is housed at another location) – See pictures at <http://www.clcpotomacregion.org/48cadillacforsale.htm> – **Best Offer** – For more info, contact John at jdwtcmd@verizon.net – Cars are located in Takoma Park, MD

NEW ARRIVAL 1965 Pillared Sedan deVille – 11K original miles – Some rust – Needs restoration except for interior which is in immaculate condition – Three-owner car – Original owner was a Vice President for Baltimore Gas & Electric – Current owner has had the car for approximately 15 years – See pictures at <http://www.clcpotomacregion.org/65cadillacforsale2.htm> – **Asking \$3,500** – For more info, contact Bud Gahs at 443-695-4417 – Car is located in Nottingham, MD (northeast suburb of Baltimore)

1968 Coupe Deville – 61,488 miles – Black with white vinyl top – Original maroon leather with maroon decor cloth interior – 100% complete, but not running – Good bones for restoration – Will include replacement hood and right front fender – See pictures at <http://www.clcpotomacregion.org/68cadillacforsale.htm> – **Asking \$2,000 obo** – For more info, contact Jeff Seifert at 301-873-4095 or jseifert@instructech.com – Car is located in Gaithersburg, MD

1969 deVille Convertible – Red exterior with white interior – Runs great – Engine replaced in 2010 – Zero rust – Always garage-kept – 60/40 bench seat and tilt steering wheel – A/C not currently working – See pictures at <http://www.clcpotomacregion.org/69cadillacforsale.htm> – **Asking \$13,000** – For more info, contact David Fields at 703-927-1320 – Car is located in Vienna, VA

1976 Eldorado Convertible – 100% complete – Not running – **Asking \$2,000 obo** – For more info, contact Randy at 301-270-7663 (w), 301-657-4544 (h) or denchroof@aol.com – Car is located in Takoma Park, MD

1985 Fleetwood Brougham Coupe – Approximately 50K original miles – Two-owner, garage-kept car owned by the current owner for the past 12 years who is now downsizing his home and garage and needs to sell – Originally an Ohio car that has been in North Carolina since 2001 – Solid original car, mechanically sound and cosmetically approximately a 6 on a scale of 1 to 10, with 10 being perfect – Paint is presentable and looks great from a distance, but is crazed on the hood – Roof and Trunk are fine, along with sides (no real issues there that a bit of polish can't fix) – Mint interior, and as new, including carpets and headliner – Original floor mats and several other sets will go with the car – HT4100 engine runs just fine with no apparent issues (all routine maintenance performed) – Needs exhaust system; has original, which needs to be replaced – Plastic bumper fillers could stand to be changed, but only two are truly cracked at this time – Passenger front and under the license plate filler are currently cracked or missing – Hood is checked and faded and could stand a repaint – Climate Control System needs evaluation – Fairly limited production model and the final year for the rear wheel drive coupe – Driver-quality Fleetwood – See pictures at <http://www.clcpotomacregion.org/85cadillacforsale.htm> – **Asking \$8,200 or best offer (motivated seller)** – For more info, contact Steve Watkins at 704-771-6741 or watkins9@carolina.rr.com – Car is located in Indian Trail, NC

Parts Wanted

1939 LaSalle Radio – For more info, contact Jack Brownell at 202-638-6300 (office), 202-746-3070 (cell) or jbrownell@douglasdev.com

1947 Series 62 Convertible Rear Fender Spears – For more info, contact Robert Schilling at 47makeover@gmail.com



**Cadillac & LaSalle Club
Potomac Region
Caddie Chronicle
April 2013**



2013 OFFICERS

NAME	POSITION(S)	PHONE NUMBER	EMAIL ADDRESS
Vince Taliano	Regional Director Newsletter Editor Website Manager	301-258-8321	vincetaliano@clcpotomacregion.org
Dan Ruby	Assistant Regional Director Car Show Coordinator	301-894-8026	danruby@clcpotomacregion.org
Jack McClow	National Director Newsletter Columnist	301-330-5417	jackmcclow@clcpotomacregion.org
Sandy Kemper	Secretary Associate Newsletter Editor Valley Forge Region Liaison	301-585-0897	sandykemper@clcpotomacregion.org
Harry Scott	Treasurer	703-791-3278	harryscott@clcpotomacregion.org
R. Scot Minesinger	Activities Director Newsletter Columnist	703-283-2021	rscotminesinger@clcpotomacregion.org
Debbie Taylor	Membership Director	301-228-2442	debbietaylor@clcpotomacregion.org